



Connection and Appendix

Market Data BMV

Version 1.1

<https://www.bmv.com.mx/es/productos-de-informacion/market-data>

Multicast Channels	1
Unicast Channels.....	1
Heartbeat.....	2
Recovery	3
Replay and Snapshot	3
Receipt and request messages service recovery.	15
IP Addresses.....	18
Security Certificate Installation Manual in Microsoft Outlook	26
Message Header.....	30
Message Block.....	31
Multicast Data Type.....	32
Heartbeat Message	33
Login Message.....	33
Replay request Message	34
Snapshot request.....	34
Login response Message	37
Replay response Message.....	38
Snapshot response message	39
Snapshot complete Message.....	40
Operation Type	41
Concertation Type	42
Operation VS Concertation	46
Marketability	47
Reference.....	47
Instrument Status.....	48
Index Status	51
Indices Components.....	51
Trend	58
System Event Codes.....	59
Catalog of Types of Public Offerings.....	61
Settlement Type.....	62
Market Data Groups	62
Markets.....	64
Derivatives Market.....	65

Snapshot Type.....	66
Type of BIVA Operations	69
BMV State Changes (Only Consolidated Feed)	69
BIVA State Changes (Only Consolidated Feed)	70
Reasons (Only Consolidated Feed)	71
Price Type (Only Consolidated Feed)	71
Contacts	72

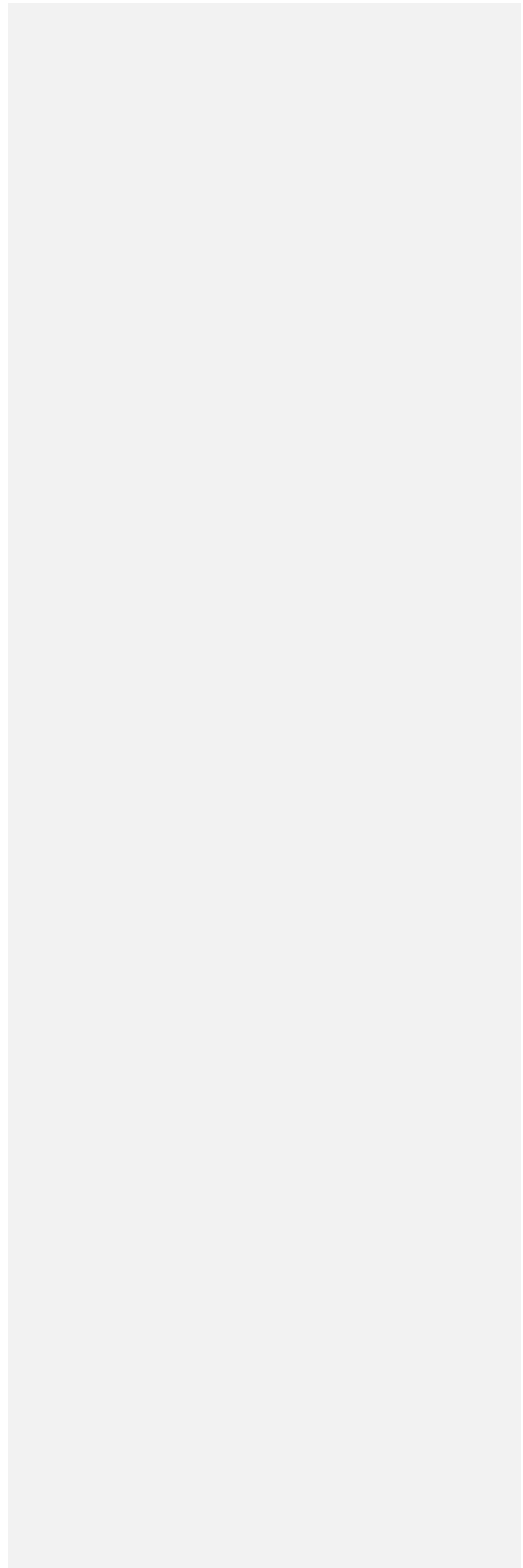

Multicast Channels

Multicast is the sending of information through multiple networks to multiple destinations simultaneously.

Before information is sent, a series of parameters must be established. To be able to receive it, it is necessary to establish what is known as "multicast group". That multicast group has an associated URL. The current version of the internet protocol, known as IPv4, reserves D type addresses for multicasting.

A multicast address is associated to a group of interested receivers. According to [RFC 3171](#) addresses from 224.0.0.0 to 239.255.255.255 are allocated to be multicast addresses. This range is formally called "D Class". The issuer sends a single datagram (from the issuer's unicast address) to the multicast address and the router will ensure that copies are made and sent to all receivers who have informed of their interest for the data of such issuer.

The multicast channel uses UDP over IPv4. Each UDP datagram will contain only one INTRA Multicast Header.

Unicast Channels

Replay and snapshots services use TCP over IPv4.

Every client intending to connect to these services must previously advise the [Market Data Support](#) group to have its IP, consumer name and password registered. The same consumer and password will be used for login into the replay and snapshots services. The credentials will be sent encrypted by email, so to display the content should follow the procedure defined in [Security Certificate Installation Manual in Microsoft Outlook](#).

The following image shows a difference between Multicast and Unicast.

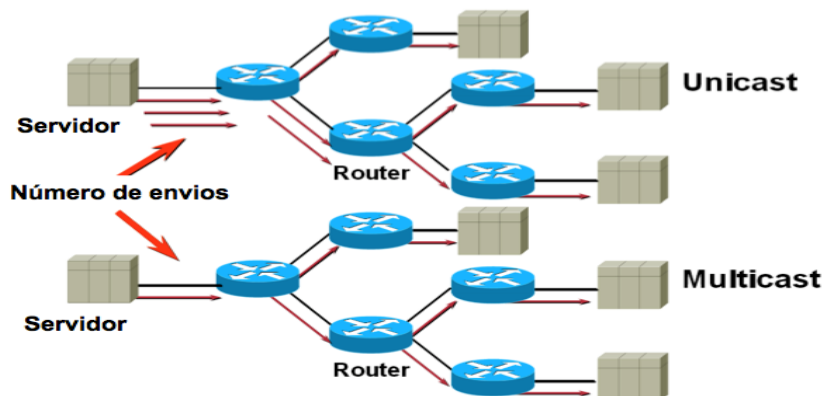

Note: The term packet will be used to refer to the Market Data information flowing through UDP and TCP/IP.

This transmission channel sends BMV Market Data information online via multicast.

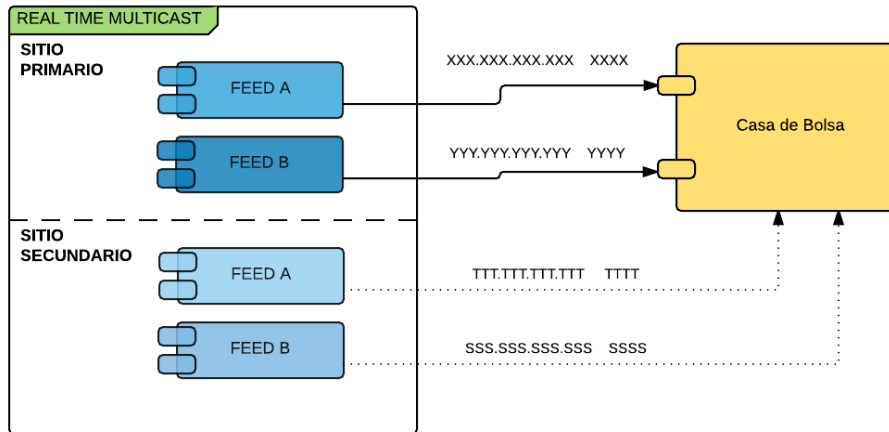

Multicast receivers will have access to two identical feeds: Feed A and Feed B. Receivers will be in charge of receiving both feeds and discarding between them to minimize loss of messages.

The information traveling through feed A and feed B is sent at the same time, but it can reach intended receivers with a small-time difference between them. It is not possible to ensure that information reaches a distribution channel before another or that it arrives at the same time.

Heartbeat

There are Heartbeat messages indicating the last sequence sent in such multicast group and port. These messages will only be disseminated in case of inactivity within such issuer and will be sent every five seconds.

Replay and Snapshot Loss of on-line flow messages

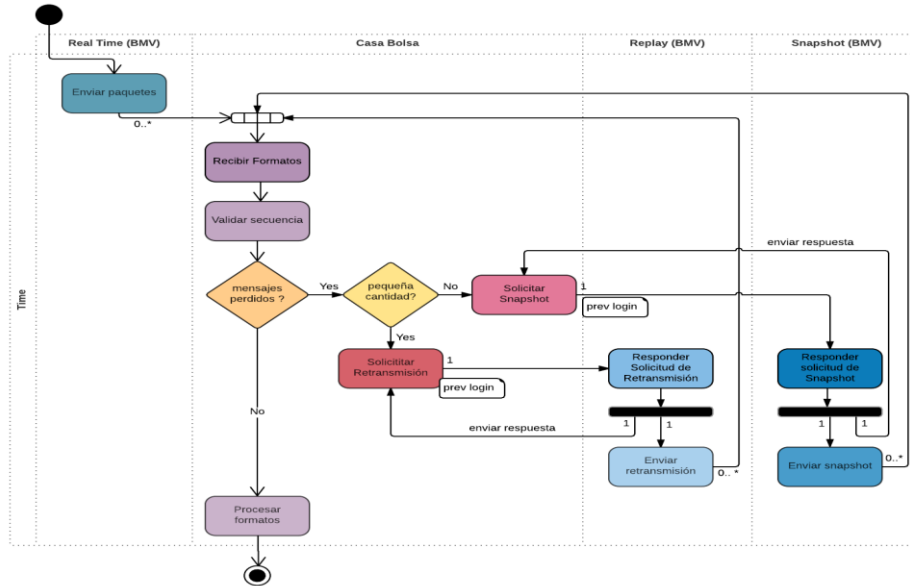

If a message loss is detected in the multicast channel, the receiver must start one of the recovery processes.

Sequence validation. A small message loss is considered when the lost amount is smaller than the limit established for replay, which in this case is 50,000 messages.

Setting up a connection

The receiver must use the relevant IP address and port to establish a TCP/IP session with any of the two unicast channels. The consumer must log in by sending a login Request message. The unicast channel server validates consumer, password, and IP address of the requesting consumer.

Once the consumer is authenticated successfully, the server will respond with a login Response message containing the field status equal to "A".

There are cases where login is not successful, instead response is sent, as shown in next image. If a receiver who has already started a session sends another login through a TCP/IP connection different from the current one, the system responds with login Response message with a status

equal to “e” and it closes the second TCP/IP connection. The first connection is not closed in this case.

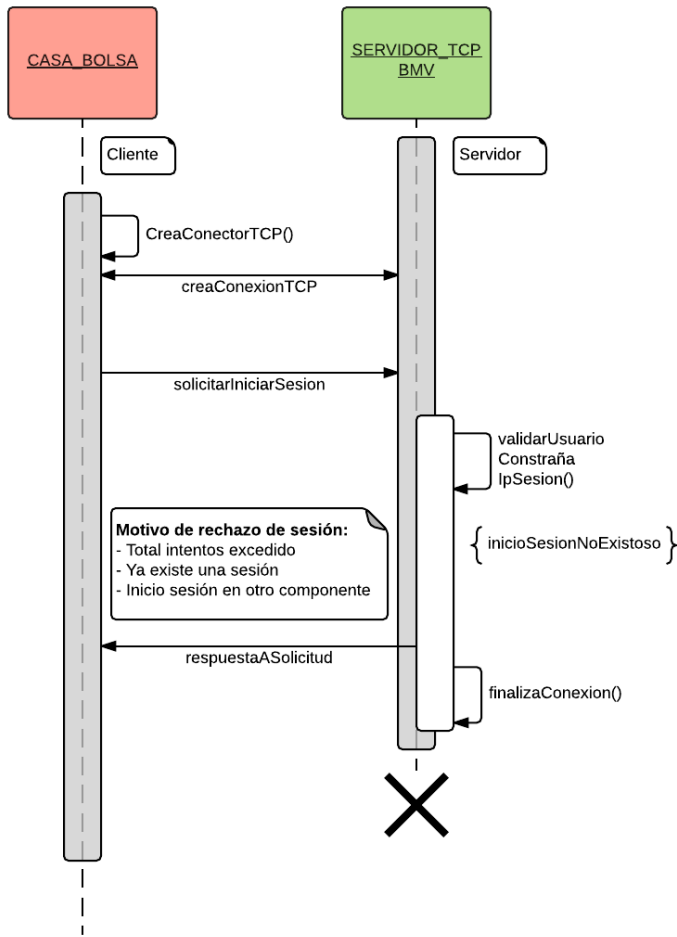

There are also cases where the Login is not successful and an answer is not sent, as it can be seen in next image.

- If a login attempt fails because the user, password or IP address of consumer is not valid or if a message is sent to the server before login is established, the server will finish the TCP/IP connection to the receiver without sending a login Response message.
- If a Replay request or Snapshot request message is not received within 5 seconds after a satisfactory login, the server will end the TCP/IP connection to the receiver without sending a message notifying the cause.

- If a login request is not received within 5 seconds after the established TCP/IP connection, the server will end the TCP/IP connection without sending a message notifying the cause.

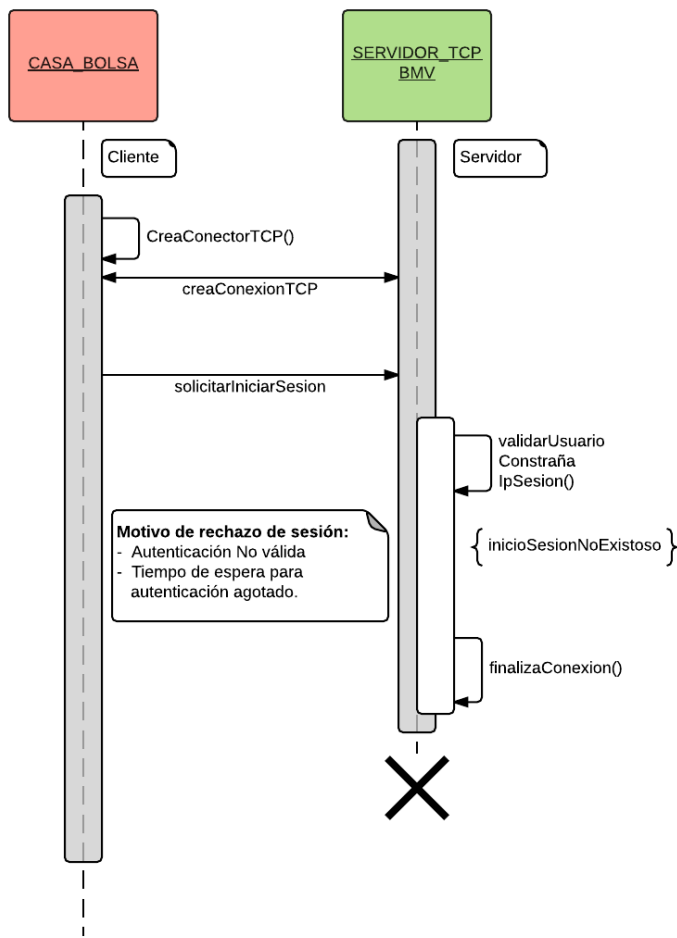

Replay Channel

The TCP replay channel must be used by the intended receivers to recover from a small-scale data loss. This allows users to request replay of a limited number of messages that have already been published by the multicast channel. The channel is configured to support replay of the last 50,000 published messages.

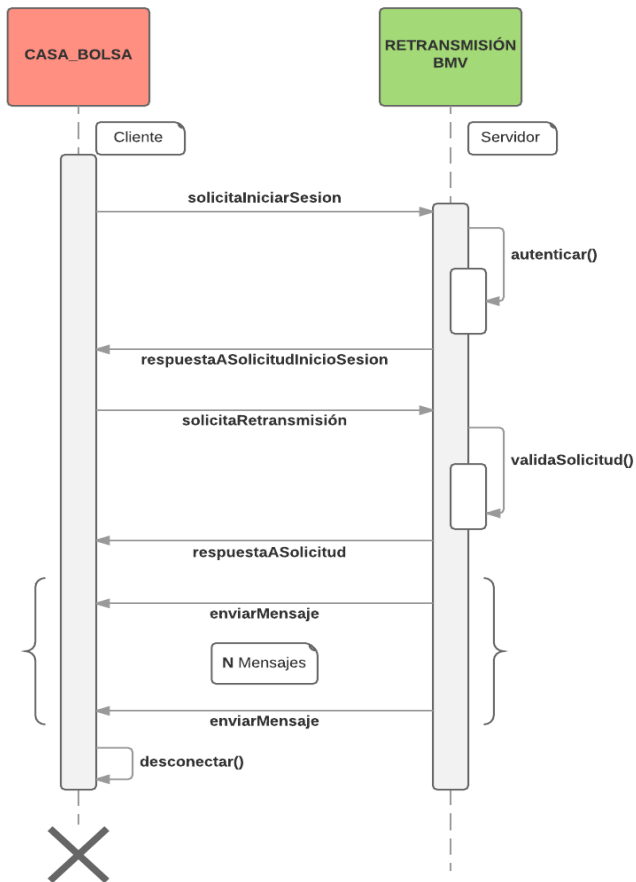

Each receiver can log in on the replay channel and request sending of a certain number of messages that have been transmitted by a certain multicast group and port, but requests may only be made a limited number of times every day. Intended receivers can request the Market Data Manager at the BMV to reset their request counter on the replay channel; this feature attempts to help managing an emergency situation and should not be used as a normal practice.

If a same consumer sends multiple requests on the replay channel, these will be processed sequentially (namely, one at a time). A replay request cannot be cancelled.

In case of a problem at the primary site where the operation cannot be reestablished, replay requests will have to be done at the backup site. BMV will be in charge of notifying the time when services will be migrated to the backup site.

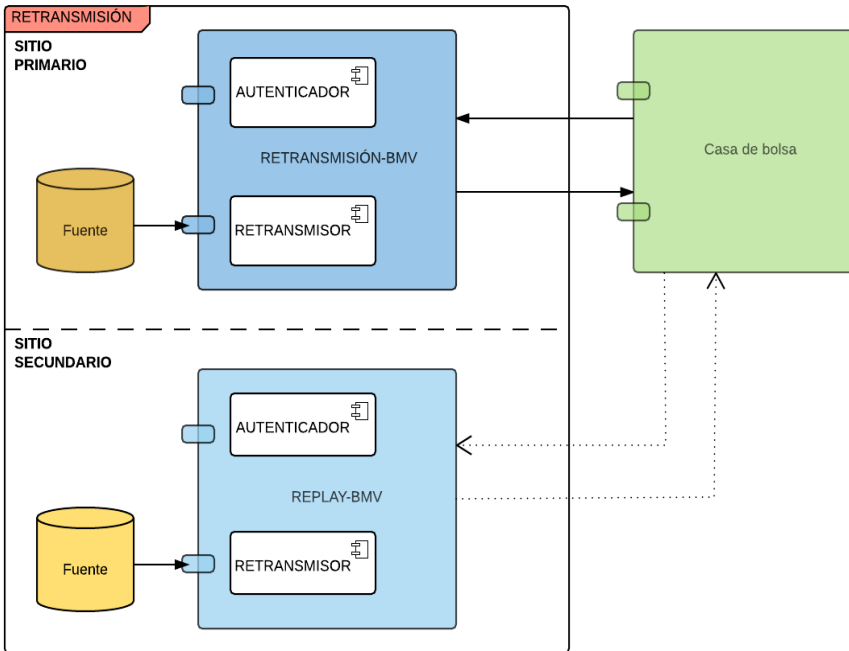

Requesting lost messages

Once connected to the replay channel, consumers can use the Replay request message to ask for the lost messages. The request must include the sequence number of the first message in the range to be replayed, together with the number of messages to be replayed.

The request will be processed from the cache server of the last messages published on the multicast channel. If the replay request includes one or more messages not located in the cache server, the entire request will be rejected with a Snapshot Response message and no message will be replayed.

Response to a replay request

The server will respond a Replay request message with a Replay response message to indicate whether replay is satisfactory or not. A value different from "A" in the status field will indicate that the request has been rejected.

In case of a satisfactory request, the server will replay the requested messages immediately after the Replay response message. The sequence numbers of the replayed messages will be the same as when these were transmitted by the multicast channel.

Terminating connection

If the receiver does not send a Logout request and it fails to terminate the connection during the following 5 seconds following the time the last lost message was sent, the server will end the TCP/IP connection.

Recovery Channel

The Snapshots TCP channel must be used by intended receivers to recover from a large-scale data loss (namely, from a late connection to the market or from a major interruption).

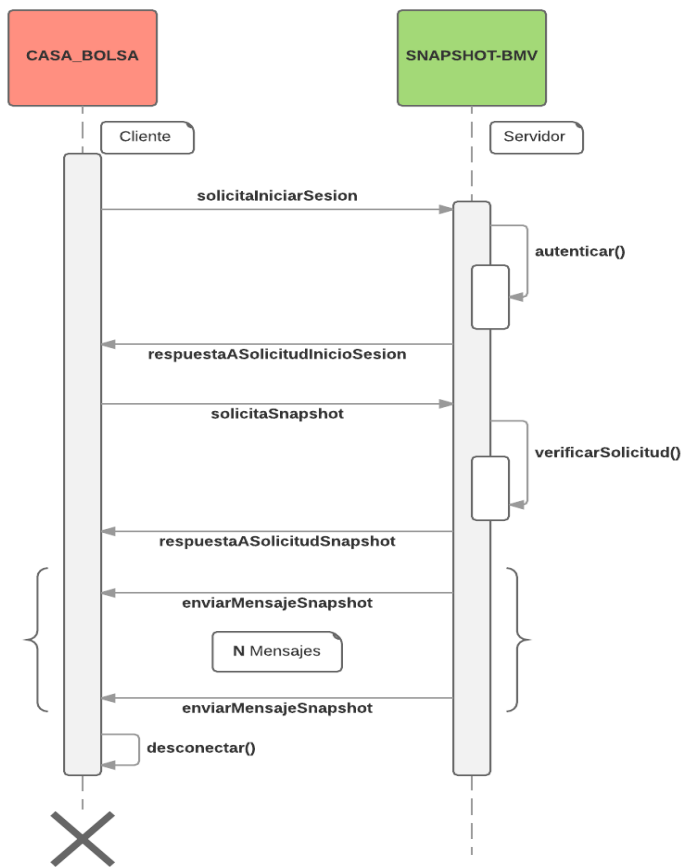

The services offered by the distribution channel are listed in the [Snapshot Type Catalog](#).

Each consumer can log in on the snapshots channel and request sending of a certain snapshot, but requests may only be done a limited number of times every day. Intended receivers may request the Market Data Manager at the BMV to reset their request counter on this channel. This feature attempts to help managing an emergency situation and it should not be used as a normal practice.

If a receiver sends multiple requests on this channel, this will be processed sequentially (that is, one at a time). A request cannot be cancelled.

In case of a problem at the primary site where the operation cannot be reestablished, the requests for snapshots will have to be made at the backup site.

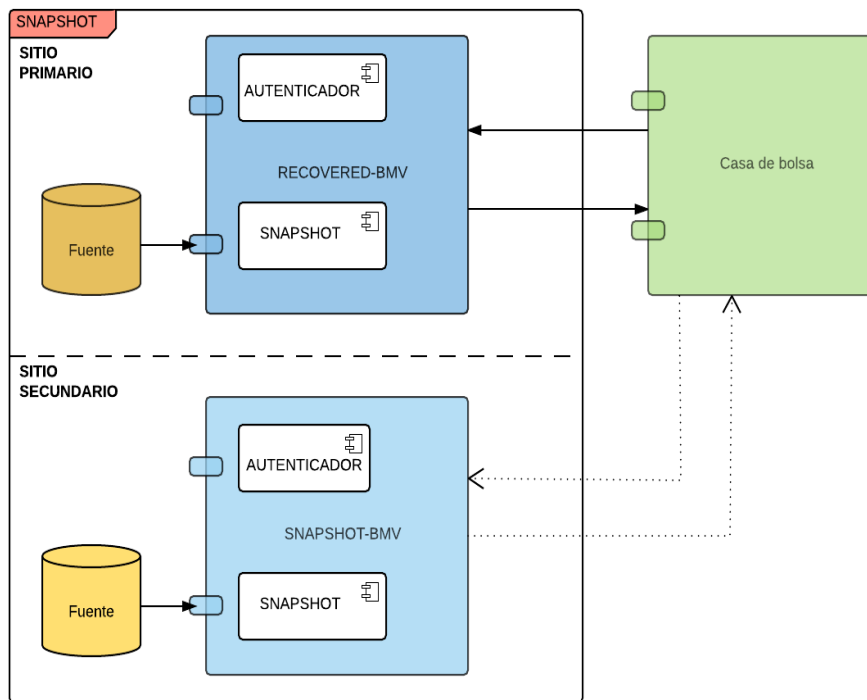

Requesting a snapshot

When the login has been accepted, then receivers may use the snapshot Request message to download the list of active instruments, request active orders, price levels, best offers or some of the last trades that have occurred at the time of the request.

The Snapshot request message contains a requested field where they send the identifier of the product for which they require the snapshot. In case the product is not sent, the request is rejected with the Snapshot Response message.

There is also a snapshot field where it is required to indicate one of the 5 types of existing snapshots. In case of not sending the snapshot type, the request is rejected with the Snapshot Response message.

The identifying field of the instrument within the snapshot Request message is not required and in case it is not sent, the request will be processed with the information of all the instruments of the product for which the snapshot is being requested.

A. List of instruments

A request from the accepted list of instruments generates a snapshot Response message, indicating that the request will be processed. After the response, the Catalogs of instruments that were disseminated will be sent at the beginning of the day by the multicast group and port of the request.

The detail of a single instrument cannot be requested. In this case, a complete group will always be sent.

When finishing to send the messages of Catalogs of instruments a Snapshot complete message will be sent, indicating that the request has been completed. In this case the end message will include the sequence with which it is synchronized regarding the flow online.

B-1. Response to an in-depth snapshot of a single instrument

An accepted request of an in-depth snapshot on an instrument generates a Snapshot response message, indicating that the request will be processed. Thereafter, an instrument Status message will be sent, followed by the orders that are active within the main book and at the end of a Snapshot complete message with the sequence with which it is synchronized regarding the channel distributing the information online.

B-2. Response to an in-depth snapshot of all instruments distributed through a multicast group and port

An accepted request of an in-depth snapshot on a multicast group and port generates a snapshot Response message, indicating that the request will be processed. Then, the messages will be sent in separate blocks by instrument. The first item to be sent will be an instrument Status message followed by the orders that are active within the main book for such instrument. When it finishes disseminating the instrument orders another instrument Status message will be sent with the following instrument to be sent, followed by its offers.

When finishing with all instruments, a Snapshot complete message will be sent with the sequence with which it is synchronized regarding the channel distributing the information online.

C-1. Response to a price level snapshot of a single instrument

An accepted request of a price level snapshot on an instrument generates a Snapshot response message, indicating that the request will be processed. Thereafter, an instrument Status message will be sent, followed by the last depth message that has been sent for such instrument

and, at the end, a Snapshot complete message with the sequence with which it is synchronized regarding the channel distributing the information online.

C-2. Response to a snapshot on all price levels instruments distributed through a multicast group and port.

An accepted request of a price levels snapshot over a multicast group and port indicating the request will be processed. Next, a separately block messages separated by instrument will be sent. First, the instrument's status followed by the last depth message sent for that particular instrument. When instrument's depth message is complete, another instrument's status will be sent for that instrument. A last instrument status will be delivered when depth message diffusion is done, same that will contain next instrument followed by message depth.

When all instruments are done, a snapshot complete message will be sent, containing the sequence with which synchronizes with respect to the online information distributing channel.

D-1. Response to a snapshot for trades on a single instrument.

An accepted request of a trades snapshot on an instrument generates a snapshot response message, indicating that the request will be processed. Thereafter, an instrument Status message will be sent, followed by the quantity of trades that may have been generated. The transactions to be stored will be both the additions and deletions of trades. When the trades finished sending, a Snapshot complete message will be sent, where it is indicated that the transaction has ended.

D-2. Response to a snapshot for trades on all instruments distributed through a multicast group and port.

An accepted request of a trades snapshot on a multicast group and port generates a snapshot response message indicating that the request will be processed. Then, the messages will be sent in separate blocks by instrument. The first item to be sent will be an instrument Status message followed by the quantity of trades that may have been generated. After the dissemination of trades ends, another instrument status message will be sent with the following instrument to be sent, followed by its relevant trades.

When finishing with all instruments, a Snapshot completed message will be sent.

E-1. Response to a snapshot for best offers on a single instrument.

An accepted request of a snapshot of best offers on an instrument generates a snapshot Response message indicating that the request will be processed. Thereafter, an instrument Status message will be sent, followed by two messages indicating best offer by side of the instrument and, at the end, a Snapshot completed message with the sequence with which it is synchronized regarding the channel distributing the information online.

E-2. Response to a snapshot of all instrument's best offers distributed through a multicast group and port.

An accepted request of a snapshot of best offers on a multicast group and port generates a snapshot Response message, indicating that the request will be processed. Then, the messages will be sent in separate blocks by instrument. The first item to be sent will be an instrument Status message followed by the best offer messages of the instrument. After the dissemination of the best offer messages, another instrument Status message will be sent with the following instrument to be sent.

When finishing with all instruments, a Snapshot complete message will be sent with the sequence with which it is synchronized regarding the channel distributing the information online.

F-1. Response to an instrument's catalog combined snapshot, in-depth messages and single instrument trades.

An accepted request of an instrument's catalog combined snapshot, in-depth messages and trades on an instrument generates a Snapshot response message, indicating the request will be processed. Thereafter, an instrument's catalog message will be sent, followed by the status message, followed by the active orders within the main book and the instrument's trades and finally a complete snapshot message with the sequence with which synchronizes with respect to the online information distributing channel.

F-2. Response to an instrument's catalog combined snapshot, depth messages and trades of all instruments distributed through a multicast group and port.

An accepted request of an instrument's catalog combined snapshot, depth messages and trades over a multicast group and port indicating the request will be processed. Next, a separated block messages by instrument will be sent. First, the instrument's catalog will be sent followed by the active orders within the main book and the instrument's trades. Thereafter, an instrument's catalog message will be sent, followed by the message status, shortly after, the active orders within the main book and the instrument's trades. When finished, another instrument's block messages will be sent in the previously indicated order.

When all instruments are done, a finished snapshot will be sent containing the sequence with which synchronizes with respect to the online information distributing channel.

G-1. Response to an instrument's catalog combined snapshot, last price level message and trades from a single instrument.

An accepted request of an instrument's catalog combined snapshot, last price level message and trades over an instrument generates a snapshot response message indicating request will be processed. Next, an instrument's message catalog followed by instrument status message, then the last depth message sent, followed by trades for that particular instrument and finally a snapshot complete message with the sequence synchronized with respect to the online information distribution channel.

G-2. Response to an instrument's catalog combined, the last price level message and trades over a multicast group and port.

An accepted request of an instrument's catalog combined snapshot, last price level message and trades over a multicast group and port generates a snapshot Response message, indicating that the request will be processed. Next, the messages will be sent in separate blocks by instrument. The first, the instrument's catalog will be sent followed by an instrument Status message followed by the last price level message and the instrument's trades. when finished, another instrument's block messages will be sent in the previously indicated order.

When all instruments are done, a finished snapshot will be sent containing the sequence with which synchronizes with respect to the online information distributing channel.

H-1. Response to and instrument's catalog combined, best offers and trades from a single instrument.

An accepted request of an instrument's catalog combined snapshot, best offers and trades from an instrument generates a snapshot response message, indicating that the request will be processed. Thereafter, an instrument's catalog message will be sent, followed by the status message, followed by the best postures and trades from an instrument and finally a complete snapshot message with the sequence with which synchronizes with respect to the online information distributing channel.

H-2. Response to an instrument's catalog combined, best offers and trades over a multicast group and port.

An accepted request of an instrument's catalog combined snapshot, last price level message and trades over a multicast group and port generates a snapshot Response message, indicating that the request will be processed. Next, the messages will be sent in separate blocks by instrument. The first, the instrument's catalog will be sent followed by an instrument Status message followed by the best offers message and the instrument's trades. when finished, another instrument's block messages will be sent in the previously indicated order.

When all instruments are done, a finished snapshot will be sent containing the sequence with which synchronizes with respect to the online information distributing channel.

I-1. Response to an instrument's catalog combined snapshot, full depth messages and price setter trade from single instrument.

An accepted request of an instrument's catalog combined snapshot, full depth messages and price setter trade from an instrument generates a Snapshot response message, indicating the request will be processed. Thereafter, an instrument's catalog message will be sent, followed by the status message, followed by the active orders within the main book and the price setter trade from an instrument and finally a complete snapshot message with the sequence with which synchronizes with respect to the online information distributing channel.

I-2. Response to an instrument's catalog combined snapshot, depth messages and price setter trade over a multicast group and port.

An accepted request of an instrument's catalog combined snapshot, full depth messages and price setter trade over a multicast group and port indicating the request will be processed. Next, a separated block messages by instrument will be sent. First, the instrument's catalog will be sent followed by the active orders within the main book and the instrument's trades. Thereafter, an instrument's catalog message will be sent, followed by the message status, shortly after, the active orders within the main book and the price setter trade from an instrument. When finished, another instrument's block messages will be sent in the previously indicated order.

When all instruments are done, a finished snapshot will be sent containing the sequence with which synchronizes with respect to the online information distributing channel.

J-1. Response to an instrument's catalog combined snapshot, last price level message and price setter trade from a single instrument.

An accepted request of an instrument's catalog combined snapshot, last price level message and price setter trade over an instrument generates a snapshot response message indicating request will be processed. Next, an instrument's message catalog followed by instrument status message, then the last depth message sent, followed by price setter trade for that particular instrument and finally a snapshot complete message with the sequence synchronized with respect to the online information distribution channel.

J-2. Response to an instrument's catalog combined, the last price level message and price setter trade over a multicast group and port.

An accepted request of an instrument's catalog combined snapshot, last price level message and price setter trade over a multicast group and port generates a snapshot response message, indicating that the request will be processed. Next, the messages will be sent in separate blocks by instrument. The first, the instrument's catalog will be sent followed by an instrument Status message followed by the last price level message and the price setter trade from an instrument. when finished, another instrument's block messages will be sent in the previously indicated order.

When all instruments are done, a finished snapshot will be sent containing the sequence with which synchronizes with respect to the online information distributing channel.

K-1. Response to and instrument's catalog combined, best offers and price setter trade from a single instrument.

An accepted request of an instrument's catalog combined snapshot, best offers and price setter trade from an instrument generates a snapshot response message, indicating that the request will be processed. Thereafter, an instrument's catalog message will be sent, followed by the status message, followed by the best postures and price setter trade from an instrument and finally a complete snapshot message with the sequence with which synchronizes with respect to the online information distributing channel.

K-2. Response to an instrument's catalog combined, best offers and price setter trade over a multicast group and port.

An accepted request of an instrument's catalog combined snapshot, last price level message and price setter trade over a multicast group and port generates a snapshot response message, indicating that the request will be processed. Next, the messages will be sent in separate blocks by instrument. The first, the instrument's catalog will be sent followed by an instrument Status message followed by the best offers message and the price setter trade from an instrument. When finished, another instrument's block messages will be sent in the previously indicated order.

When all instruments are done, a finished snapshot will be sent containing the sequence with which synchronizes with respect to the online information distributing channel.

Receipt and request messages service recovery.

In overview, as it has already been mentioned, the INTRA Multicast protocol for Market Data is made up of:

- On-line information service distributing the same information through two applications (known as Feeds) on different Multicast Channels.
- Replay service, allocated to the recovery of a number of messages lower than 50,000.
- Snapshots service, allocated to recovery in the event of a major loss of messages or of an untimely connection to the market.

The following section shows how each component acts after a failure occurring in one or more of them and which actions Market Data consumers may carry out.

Distribution and receipt failures on the on-line information service Failure of one of the applications in charge of distributing one of the two feeds sending the information of one of the products offered via multicast.

There are two applications distributing the same information through different Multicast Channels. Assume a scenario where one of these fails for some reason, consider Feed A, for example:

On one hand, Feed B, which remains in service, will continue to provide messages normally; namely, the flow and sending of outgoing messages will be maintained, without altering or losing the sequence of them. Once the failed service on Feed A is restored, messages continue to be sent in the same sequence where Feed B is at the time of such restoration.

In summary, how would this scenario look like with an example? Let's assume for starters that Feed A and B are working simultaneously, sending the same messages. Now, let's assume that Feed A fails after sending sequence 1,000,000 during session 1. Feed B will continue to work uninterrupted. Later on, Feed A restores its service when Feed B is in sequence 1'500,000, the message and sequence with which such Feed A will begin will be exactly that corresponding to message 1'500,000 of Feed B.

It is important to state at this point that under this scenario, the value of the session identifier field sent in all the headers of the messages sent through multicast and unicast channels will continue to be the same.

Failure in the receipt of both feeds in charge of disseminating the complete information of one of the products offered via multicast.

The receipt of messages may be naturally interrupted for short time periods if and only if during such period no messages have been generated, but as it was previously stated in the documentation, there is an administrative message called Heartbeat, which will be disseminated every 5 seconds during idle periods. As a result of the foregoing, at least one message must flow in each of the multicast channels every 5 seconds.

The periods during which at least one message must be distributed every 5 seconds are between receipt of the system Events message with code A, which shows the starting times of the systems and the receipt of the system Events message with code K, which means that the times when the systems remain operating have ended.

The failure to receive messages (including that of Heartbeat) means that a problem is in process and the Market Data support area must be consulted for such purpose in order to obtain support in diagnosing the problem.

Failure in the replay service

The replay service is made up of two applications used for message replay via unicast. One of these is called primary and another is called secondary or alternate. All replay requests must be directed to the primary application.

Let's assume a scenario where it is not possible to establish communication with the primary replay application, namely, it is not possible to make a replay request. After three attempts to connect to the primary service with an interval of 5 seconds between connection attempts, the connection must be attempted with the alternate service. If the alternate service answers the requests, then requests should continue to be made there.

If there is no answer neither from the primary service or the alternate service, then the BMV's Market Data support team must be contacted in order to learn about the service status.

Regarding the secondary replay application, this will only be available for users if the primary application is not available due to a failure. If requests are made to the alternate service and the primary service is available, then the requests will be rejected.

At this point, it is important to state that in this scenario the value of the session identifier field sent in all the headers of the messages sent through multicast and unicast channels will continue to be the same.

Failure in the snapshots service

The snapshots service consists of two applications allocated to the transmission of messages via unicast. One of these is called primary and another is called secondary or alternate. All snapshot requests must be directed to the primary application.

Assume the scenario where it is not possible to establish communication with the primary snapshot application. After three connection attempts to the primary service with a 5-second interval between attempts, connection to the alternate service must be attempted. If the alternate service answers the requests, then the requests will continue to be made there.

In the event neither the primary service nor the alternate service answers, then the BMV's Market Data support team must be contacted to learn about the service status.

Regarding the secondary snapshot application, this will only be available to the users if the primary application is not available due to a failure. In the event requests are made to the alternate service and the primary service is available, then the requests will be rejected.

It is important to state now that under this scenario the value of the session identifier field sent in all the headers of the messages sent through multicast and unicast channels will continue to be the same.

Change of session and sequence reset in the various communication channels.

When a problem occurs in the dissemination of Market Data information and for which reason the sequences need to be reset, the procedure will be as follows:

- Both multicast channels and unicast channels will start to send a new value in the session identifier field in the header, starting again from sequence one.
- Replay requests will be processed on this new sequencer, losing the history of messages that have been disseminated with the previous session.
- The snapshots service will not lose the history of messages and it may continue to process the requests, except that when it sends the Snapshot complete message, it will disclose the new session and sequences of the on-line flow.

It is of utmost importance that all receivers of the INTRA Multicast protocol for Market Data bear in mind such considerations in their relevant developments to properly use and request the information contained in the messages.

Index

1. [Multicast](#)
 1. [Production](#)
 2. [DRP](#)
 3. [Test](#)
2. [Recovery Services \(TCP/IP\)](#)
3. [Source IP](#)
4. [Rendezvous Point](#)
 1. [From Financial Network](#)
 2. [From Collocation and Equinix](#)
 3. [From VPN](#)

Multicast

Production

Product	FEED A		FEED B	
	IP	PORT	IP	PORT
1	239.100.100.1	12121	239.100.200.1	12122
2	239.100.100.2	12121	239.100.200.2	12122
3	239.100.100.3	12121	239.100.200.3	12122
4	239.100.100.4	12121	239.100.200.4	12122
5	239.100.100.5	12121	239.100.200.5	12122
6	239.100.100.6	12121	239.100.200.6	12122
7	239.100.100.7	12121	239.100.200.7	12122
8	239.100.100.8	12121	239.100.200.8	12122
9	239.100.100.9	12121	239.100.200.9	12122
10	239.100.100.10	12121	239.100.200.10	12122
11	239.100.100.11	12121	239.100.200.11	12122
12	239.100.100.12	12121	239.100.200.12	12122

13	239.100.100.13	12121	239.100.200.13	12122
14	239.100.100.14	12121	239.100.200.14	12122
15	239.100.100.15	12121	239.100.200.15	12122
16	239.100.100.16	12121	239.100.200.16	12122
17	239.100.100.17	12121	239.100.200.17	12122
18	239.100.100.18	12121	239.100.200.18	12122
19	239.100.100.19	12121	239.100.200.19	12122
20	239.100.100.20	12121	239.100.200.20	12122
21	239.100.100.21	12121	239.100.200.21	12122
22	239.100.100.22	12121	239.100.200.22	12122
23	239.100.100.23	12121	239.100.200.23	12122
24	239.100.100.24	12121	239.100.200.24	12122
25	239.100.100.25	12121	239.100.200.25	12122
26	239.100.100.26	12121	239.100.200.26	12122
27	239.100.100.27	12121	239.100.200.27	12122
28	239.100.100.28	12121	239.100.200.28	12122
29	239.100.100.29	12121	239.100.200.29	12122
32	239.100.100.32	12121	239.100.200.32	12122
33	239.100.100.33	12121	239.100.200.33	12122
34	239.100.100.34	12121	239.100.200.34	12122
40	239.100.100.40	12121	239.100.200.40	12122

[Menu](#)

DRP

Product	FEED A		FEED B	
	IP	PORT	IP	PORT
1	239.150.100.1	12131	239.150.200.1	12132
2	239.150.100.2	12131	239.150.200.2	12132
3	239.150.100.3	12131	239.150.200.3	12132
4	239.150.100.4	12131	239.150.200.4	12132
5	239.150.100.5	12131	239.150.200.5	12132
6	239.150.100.6	12131	239.150.200.6	12132
7	239.150.100.7	12131	239.150.200.7	12132
8	239.150.100.8	12131	239.150.200.8	12132
9	239.150.100.9	12131	239.150.200.9	12132
10	239.150.100.10	12131	239.150.200.10	12132
11	239.150.100.11	12131	239.150.200.11	12132
12	239.150.100.12	12131	239.150.200.12	12132
13	239.150.100.13	12131	239.150.200.13	12132
14	239.150.100.14	12131	239.150.200.14	12132
15	239.150.100.15	12131	239.150.200.15	12132
16	239.150.100.16	12131	239.150.200.16	12132
17	239.150.100.17	12131	239.150.200.17	12132
18	239.150.100.18	12131	239.150.200.18	12132

19	239.150.100.19	12131	239.150.200.19	12132
20	239.150.100.20	12131	239.150.200.20	12132
21	239.150.100.21	12131	239.150.200.21	12132
22	239.150.100.22	12131	239.150.200.22	12132
23	239.150.100.23	12131	239.150.200.23	12132
24	239.150.100.24	12131	239.150.200.24	12132
25	239.150.100.25	12131	239.150.200.25	12132
26	239.150.100.26	12131	239.150.200.26	12132
27	239.150.100.27	12131	239.150.200.27	12132
28	239.150.100.28	12131	239.150.200.28	12132
29	239.150.100.29	12131	239.150.200.29	12132
32	239.150.100.32	12131	239.150.200.32	12132
33	239.150.100.33	12131	239.150.200.33	12132
34	239.150.100.34	12131	239.150.200.34	12132
40	239.150.100.40	12131	239.150.200.40	12132

[Menu](#)

Test

Product	FEED A		FEED B	
	IP	PORT	IP	PORT
1	239.200.100.1	12141	239.200.200.1	12142
2	239.200.100.2	12141	239.200.200.2	12142
3	239.200.100.3	12141	239.200.200.3	12142
4	239.200.100.4	12141	239.200.200.4	12142
5	239.200.100.5	12141	239.200.200.5	12142
6	239.200.100.6	12141	239.200.200.6	12142
7	239.200.100.7	12141	239.200.200.7	12142
8	239.200.100.8	12141	239.200.200.8	12142
9	239.200.100.9	12141	239.200.200.9	12142
10	239.200.100.10	12141	239.200.200.10	12142
11	239.200.100.11	12141	239.200.200.11	12142
12	239.200.100.12	12141	239.200.200.12	12142
13	239.200.100.13	12141	239.200.200.13	12142
14	239.200.100.14	12141	239.200.200.14	12142
15	239.200.100.15	12141	239.200.200.15	12142
16	239.200.100.16	12141	239.200.200.16	12142
17	239.200.100.17	12141	239.200.200.17	12142
18	239.200.100.18	12141	239.200.200.18	12142
19	239.200.100.19	12141	239.200.200.19	12142

20	239.200.100.20	12141	239.200.200.20	12142
21	239.200.100.21	12141	239.200.200.21	12142
22	239.200.100.22	12141	239.200.200.22	12142
23	239.200.100.23	12141	239.200.200.23	12142
24	239.200.100.24	12141	239.200.200.24	12142
25	239.200.100.25	12141	239.200.200.25	12142
26	239.200.100.26	12141	239.200.200.26	12142
27	239.200.100.27	12141	239.200.200.27	12142
28	239.200.100.28	12141	239.200.200.28	12142
29	239.200.100.29	12141	239.200.200.29	12142
32	239.200.100.32	12141	239.200.200.32	12142
33	239.200.100.33	12141	239.200.200.33	12142
34	239.200.100.34	12141	239.200.200.34	12142
40	239.200.100.40	12141	239.200.200.40	12142

[Menu](#)

Recovery Services (TCP/IP)

Environment	IP	PORT
Production	10.100.196.78	52001
Production	10.100.196.79	52002
DRP	10.100.236.143	51001
DRP	10.100.236.144	51002
Test	10.100.236.141	50002
Test	10.100.236.142	50001

[Menu](#)

Source IP

Environment	SOURCE IP
Production	10.239.196.0 / 24
DRP	10.239.236.0 / 24
Test	10.239.236.0 / 24

Rendezvous Point

[Menu](#)

From financial network

Environment	FEED A	FEED B
Production	10.239.196.248 o 10.239.196.249*	10.239.196.252
DRP	10.239.236.253	10.239.236.252
Test	10.239.236.253	10.239.236.252

* Communications area BMV confirm the RP depending on the aggregation router.

[Menu](#)

From Collocation and Equinix

Environment	FEED A	FEED B
Production	10.239.196.247	10.239.196.246

[Menu](#)

From VPN

Environment	FEED A
Production	10.239.196.245
DRP	10.239.236.245
Test	10.239.236.245

Introduction

Description of the procedure to install a security certificate in the (Microsoft Outlook) mail, to correctly receive and read the encrypted information.

Pre-requirements

Must have previously obtain the "keystore_mcast.p12" and password associated to the same certificate. In case you do not possess either one, please send a requirement to the Market Data Support team.

Procedure

1. Login to Microsoft Outlook
2. Go to "Files" and click on "Options".

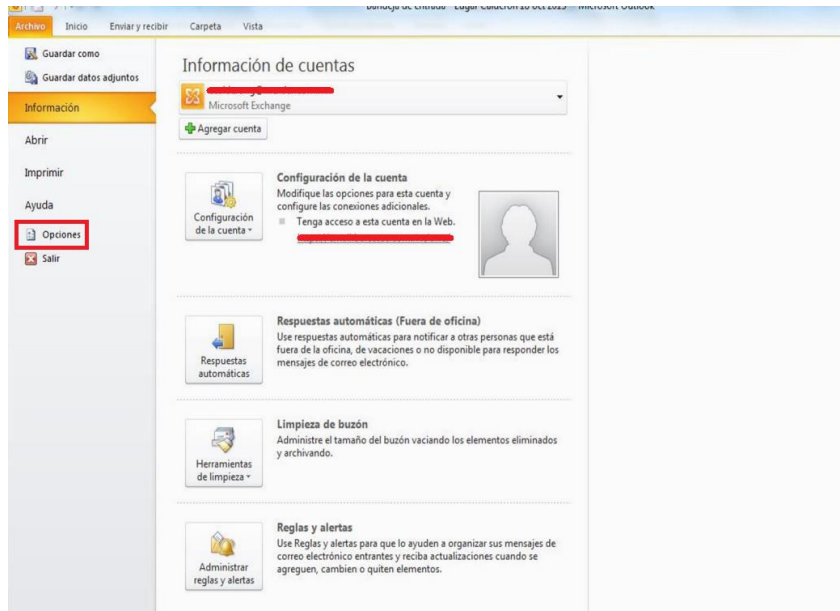

3. Go to the "Trust Center" button, then click on "Trust center settings".

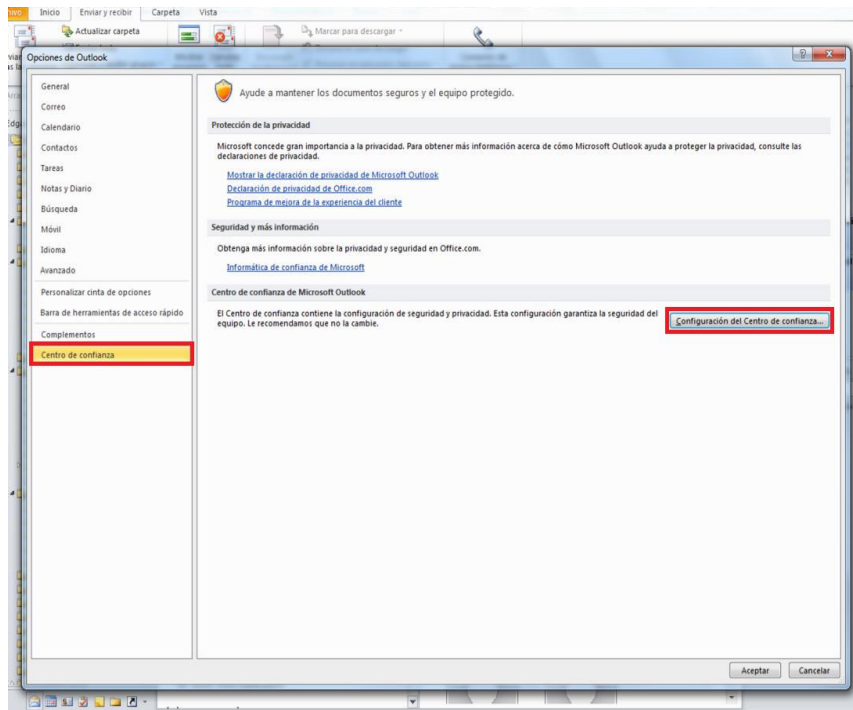

4. Search for the "E-mail Security" option and click on "Import/Export".

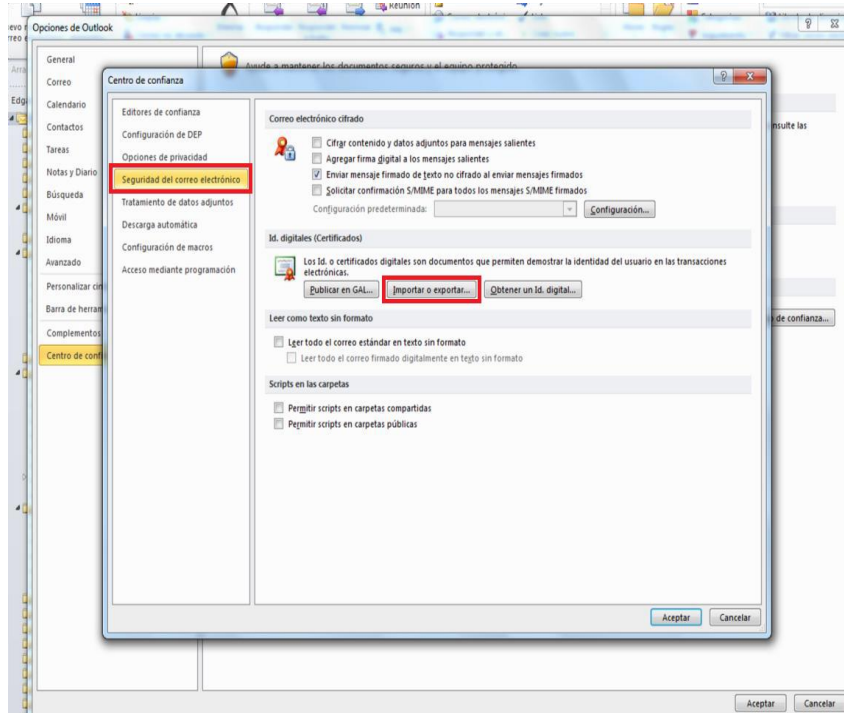

5. Inside the "Import/Export" option fill in the information based on the following:
- Inside the "Import/Export" option, click on "Browse" and select the "keystore_mcast.p12" file (this file must have been provided to you by the Market Data Support team).
 - In "Password", introduce the previously provided password by the Market Data Support team.
 - In "Digital ID. Name", assign a name (suggested name is "bmvcorp")
 - Click accept.

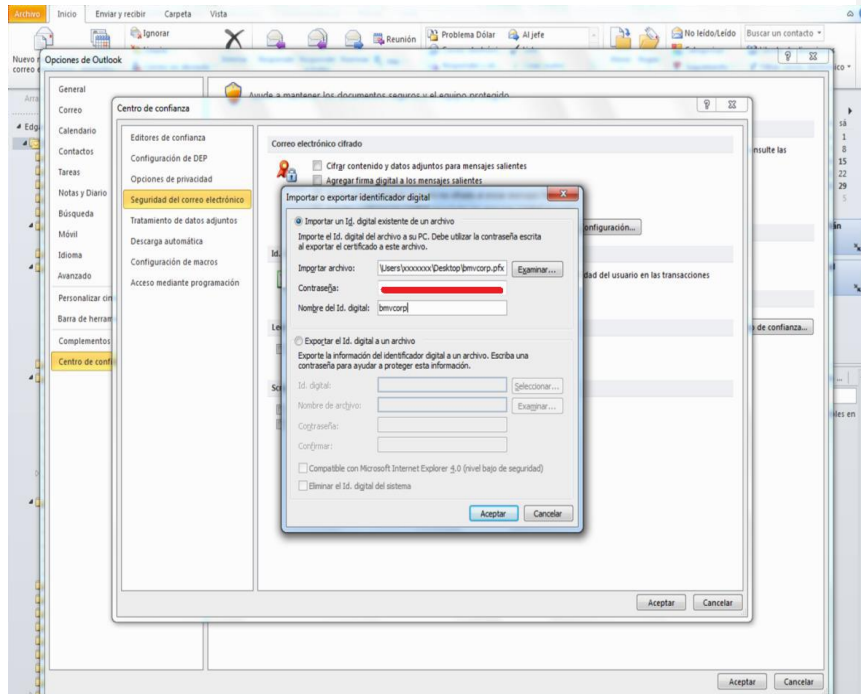

Header

The INTRA Multicast Header is used to deliver all administrative and application messages in the three different channels. The INTRA Multicast Header may contain zero, one or more messages. While a INTRA Multicast Header may contain multiple application messages, it will never contain more than one administrative message and it will not contain a mixture of both either.

Campo	Offset	Size	Value	Description
Length	0	2	Int16	Packet length, including header and all attached messages
Total Messages	2	1	Int8	Number of messages after the header
Market Data Group	3	1	Int8	See Market Data Groups Catalog
Session	4	1	Int8	Current session identifier
Sequence Number	5	4	Int32	Sequence number of the first message attached to header
Date-Time	9	8	Timestamp(3)	Date and time the packet is created
Total:		17		

Message Block

Block

First field of a message block is the message length. The first message block will start immediately after the header. Subsequent message blocks will start after the last byte of the previous message block.

Field	Offset	Size	Value	Description
Message length	*	2	Int16	Indicates message length contained in this message block
Total Messages	*	*		Message content with variable length

The following image shows a representation of bits in a two-message example in a packet. The first message with 10 bytes length and second with 5 bytes.

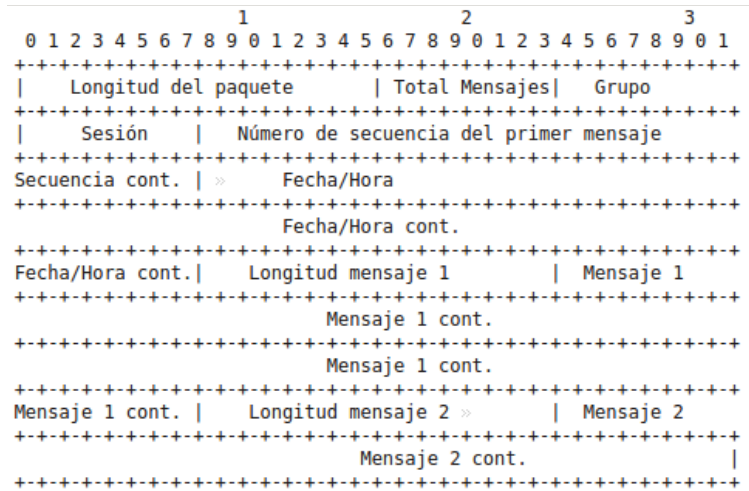

Multicast Data Type

All integer fields are ordered under the big-endian system and have a sign.

All ALPHA fields are ISO 8859-1, left aligned and filled on the right with spaces.

Table shows the different types of data used in INTRA Multicast for Market Data.

Type of data	Length in Bytes	Initial Range	Final Range	Description
ALPHA	Variable			Those fields use standard ISO 8859-1 characters bytes. Justified to the left and blank spaces to the right.
Timestamp(1)	8	0	9223372036854775807	8 bytes to indicate the date.
Timestamp(2)	8	0	9223372036854775807	8 bytes to indicate date and time, with a precision of seconds.
Timestamp(3)	8	0	9223372036854775807	8 bytes to indicate date and time, with a precision of milliseconds.
Int8	1	-128	127	8 integer bits with sign
Int16	2	-32768	32767	16 integer bits with sign
Int32	4	-2147483648	2147483647	32 integer bits with sign
Int64	8	-9223372036854775808	9223372036854775807	64 integer bits with sign
Price(4)	4	-2147483648	2147483647	32 integer bits with sign, where the last 4 positions indicate the decimal part. The decimal part is the one marked in red

Price(8)	8	- 9223372036854775808	9223372036854775807	64 integer bits with sign, where the last 8 positions are the decimal part and redmarked
----------	---	--------------------------	---------------------	------------------------------------------------------------------------------------------

Heartbeat Message

Heartbeat Message

The Heartbeat message will be sent every five seconds and only be disseminated in case of group inactivity. This message indicates the last sent sequence in a particular multicast group and port.

The same contains only a header with: Number of messages equal to zero and the last sent message sequence.

Login Message

Login Message

Field	Offset	Size (byte)	Type	Description				
Length	0	1	Int8	Message length including this field				
Message type	1	1	ALPHA	<table border="1"> <thead> <tr> <th>Value</th> <th>(Hexadecimal) value</th> </tr> </thead> <tbody> <tr> <td>!</td> <td>(0x21)</td> </tr> </tbody> </table>	Value	(Hexadecimal) value	!	(0x21)
Value	(Hexadecimal) value							
!	(0x21)							
Market Data Group	2	1	Int8	See Market Data Groups Catalog				
User	3	6	ALPHA	User assigned to receiver				
Password	9	10	ALPHA	Password assigned to receiver. In case of size less than 10, must fill with blank spaces to the right.				
Total:		19						

Replay request Message

Replay request Message

Field	Offset	Size (byte)	Type	Description				
Length	0	1	Int8	Message length including this field				
Message type	1	1	ALPHA	<table border="1"> <thead> <tr> <th>Value</th> <th>(Hexadecimal) value</th> </tr> </thead> <tbody> <tr> <td>#</td> <td>(0x23)</td> </tr> </tbody> </table>	Value	(Hexadecimal) value	#	(0x23)
Value	(Hexadecimal) value							
#	(0x23)							
Market Data Group	2	1	Int8	See Market Data Groups Catalog				
First Message	3	4	Int32	Sequence number of the first message intended to recover				
Quantity	7	2	Int16	Quantity of requested messages				
Total:		9						

Snapshot request

Snapshot request

Field	Offset	Size (byte)	Type	Description				
Length	0	1	Int8	Message length including this field				
Message type	1	1	ALPHA	<table border="1"> <thead> <tr> <th>Value</th> <th>(Hexadecimal) value</th> </tr> </thead> <tbody> <tr> <td>\$</td> <td>(0x24)</td> </tr> </tbody> </table>	Value	(Hexadecimal) value	\$	(0x24)
Value	(Hexadecimal) value							
\$	(0x24)							
Market Data Group	2	1	Int8	See Market Data Groups Catalog				

Instrument ID	3	4	Int32	Instrument identifier to which request is related. For requests not related to any instrument, this field will only contain zeros.
Snapshot type	7	1	Int8	See Snapshot Type Catalog . The types of Snapshot allowed by each of the multicast product are listed in the Snapshot by Product Catalog
Total:	8			

Snapshot Indices request

Field	Offset	Size (byte)	Type	Description				
Length	0	1	Int8	Message length including this field				
Message type	1	1	ALPHA	<table border="1"> <thead> <tr> <th>Value</th> <th>(Hexadecimal) value</th> </tr> </thead> <tbody> <tr> <td>-</td> <td>(0x2d)</td> </tr> </tbody> </table>	Value	(Hexadecimal) value	-	(0x2d)
Value	(Hexadecimal) value							
-	(0x2d)							
Market Data Group	2	1	Int8	See Market Data Groups Catalog				
Component	3	2	ALPHA					
Recovery hour	5	8	Timestamp(2)	Hour from which to recover the index. If it is zero will send all the information of the sample of the day.				
Total:	13							

Snapshot consolidated Feed request

Field	Offset	Size (byte)	Type	Description				
Length	0	1	Int8	Message length including this field				
Message type	1	1	ALPHA	<table border="1"> <thead> <tr> <th>Value</th> <th>(Hexadecimal) value</th> </tr> </thead> <tbody> <tr> <td>-</td> <td>(0x5f)</td> </tr> </tbody> </table>	Value	(Hexadecimal) value	-	(0x5f)
Value	(Hexadecimal) value							
-	(0x5f)							
Market Data Group	2	1	Int8	See Market Data Groups Catalog				
Instrument ID	3	4	Int32	Instrument identifier to which request is related. For requests not related to any instrument, this field will only contain zeros.				
Snapshot type	7	1	Int8	See Snapshot Type Catalog . The types of Snapshot allowed by each of the multicast product are listed in the Snapshot by Product Catalog				
Origin	8	1	ALPHA	Origin of the message: M (BMV), I (BIVA), A (Both)				
Total:		9						

Login response Message

Login response Message

Field	Offset	Size (byte)	Type	Description										
Message type	0	1	ALPHA	<table border="1"> <thead> <tr> <th>Value</th> <th>(Hexadecimal) value</th> </tr> </thead> <tbody> <tr> <td>&</td> <td>(0x26)</td> </tr> </tbody> </table>	Value	(Hexadecimal) value	&	(0x26)						
				Value	(Hexadecimal) value									
&	(0x26)													
Status	1	1	ALPHA	<table border="1"> <thead> <tr> <th>Value</th> <th>Meaning</th> </tr> </thead> <tbody> <tr> <td>A</td> <td>Accepted session</td> </tr> <tr> <td>B</td> <td>Invalid Market Data group</td> </tr> <tr> <td>C</td> <td>Login on another channel</td> </tr> <tr> <td>D</td> <td>Unavailable service (In case of intermittence from requested service, contact our support team)</td> </tr> </tbody> </table>	Value	Meaning	A	Accepted session	B	Invalid Market Data group	C	Login on another channel	D	Unavailable service (In case of intermittence from requested service, contact our support team)
				Value	Meaning									
				A	Accepted session									
				B	Invalid Market Data group									
C	Login on another channel													
D	Unavailable service (In case of intermittence from requested service, contact our support team)													
Total:	2													

Replay response Message

Replay response Message

Field	Offset	Size (byte)	Type	Description																		
Message type	0	1	ALPHA	<table border="1"> <thead> <tr> <th>Value</th> <th>(Hexadecimal) value</th> </tr> </thead> <tbody> <tr> <td>*</td> <td>(0x2A)</td> </tr> </tbody> </table>	Value	(Hexadecimal) value	*	(0x2A)														
Value	(Hexadecimal) value																					
*	(0x2A)																					
Market Data Group	1	1	Int8	See Market Data Groups Catalog																		
First message	2	4	Int32	Sequence number of the first message to be transmitted. Zero when request not accepted.																		
Quantity	6	2	Int16	Number of messages to be replayed. Zero when request not accepted.																		
Status	8	1	ALPHA	<table border="1"> <thead> <tr> <th>Value</th> <th>Meaning</th> </tr> </thead> <tbody> <tr> <td>A</td> <td>Accepted request</td> </tr> <tr> <td>B</td> <td>Invalid Market data group</td> </tr> <tr> <td>D</td> <td>Unavailable Service (Intermittence over requested service, we suggest contacting our support team)</td> </tr> <tr> <td>E</td> <td>Not logged in</td> </tr> <tr> <td>F</td> <td>Surpass requests limit</td> </tr> <tr> <td>G</td> <td>Out of range</td> </tr> <tr> <td>J</td> <td>First invalid message</td> </tr> <tr> <td>K</td> <td>Invalid quantity</td> </tr> </tbody> </table>	Value	Meaning	A	Accepted request	B	Invalid Market data group	D	Unavailable Service (Intermittence over requested service, we suggest contacting our support team)	E	Not logged in	F	Surpass requests limit	G	Out of range	J	First invalid message	K	Invalid quantity
Value	Meaning																					
A	Accepted request																					
B	Invalid Market data group																					
D	Unavailable Service (Intermittence over requested service, we suggest contacting our support team)																					
E	Not logged in																					
F	Surpass requests limit																					
G	Out of range																					
J	First invalid message																					
K	Invalid quantity																					
Total:		9																				

Snapshot response message

Snapshot response message

Field	Offset	Size (byte)	Type	Description																						
Message type	0	1	ALPHA	<table border="1"> <thead> <tr> <th>Value</th> <th>(Hexadecimal) Value</th> </tr> </thead> <tbody> <tr> <td>+</td> <td>(0x2B)</td> </tr> </tbody> </table>	Value	(Hexadecimal) Value	+	(0x2B)																		
Value	(Hexadecimal) Value																									
+	(0x2B)																									
Quantity of messages	1	4	Int32	Number of messages to be transmitted in order to attend snapshot request. Also included, instrument status messages and Snapshot complete final messages. The same will be zero for not accepted request.																						
Status	5	1	ALPHA	<table border="1"> <thead> <tr> <th>Value</th> <th>Meaning</th> </tr> </thead> <tbody> <tr> <td>A</td> <td>Accepted request</td> </tr> <tr> <td>B</td> <td>Invalid Market Data group</td> </tr> <tr> <td>D</td> <td>Unavailable service (Experiencing intermittence on requested service, contact support team)</td> </tr> <tr> <td>E</td> <td>Not logged in</td> </tr> <tr> <td>F</td> <td>Surpass requests limit</td> </tr> <tr> <td>H</td> <td>Invalid SNAPSHOT type</td> </tr> <tr> <td>I</td> <td>Invalid identifier instrument. Not included on the market data instruments list group.</td> </tr> <tr> <td>L</td> <td>Market Data combination/ Unavailable snapshot type</td> </tr> <tr> <td>M</td> <td>Empty information from requested instrument.</td> </tr> <tr> <td>S</td> <td>Invalid sample.</td> </tr> </tbody> </table>	Value	Meaning	A	Accepted request	B	Invalid Market Data group	D	Unavailable service (Experiencing intermittence on requested service, contact support team)	E	Not logged in	F	Surpass requests limit	H	Invalid SNAPSHOT type	I	Invalid identifier instrument. Not included on the market data instruments list group.	L	Market Data combination/ Unavailable snapshot type	M	Empty information from requested instrument.	S	Invalid sample.
Value	Meaning																									
A	Accepted request																									
B	Invalid Market Data group																									
D	Unavailable service (Experiencing intermittence on requested service, contact support team)																									
E	Not logged in																									
F	Surpass requests limit																									
H	Invalid SNAPSHOT type																									
I	Invalid identifier instrument. Not included on the market data instruments list group.																									
L	Market Data combination/ Unavailable snapshot type																									
M	Empty information from requested instrument.																									
S	Invalid sample.																									

Snapshot type	6	1	Int8	See Snapshot Type Catalog . The types of Snapshot allowed by each of the multicast product are listed in the Snapshot by Product Catalog
Total:		7		

Snapshot complete Message

Snapshot complete Message

Field	Offset	Size (byte)	Type	Description				
Message type	0	1	ALPHA	<table border="1"> <thead> <tr> <th>Value</th> <th>(Hexadecimal) value</th> </tr> </thead> <tbody> <tr> <td>?</td> <td>(0x3F)</td> </tr> </tbody> </table>	Value	(Hexadecimal) value	?	(0x3F)
Value	(Hexadecimal) value							
?	(0x3F)							
Sequence number	1	4	Int32	Sequence number on to which the snapshot synchronizes with respect to the online channel.				
Market Data Group	5	1	Int8	See Market Data Groups Catalog				
Snapshot type	6	1	Int8	See Snapshot Type Catalog . The types of Snapshot allowed by each of the multicast product are listed in the Snapshot by Product Catalog				
Total:		7						

Appendix

- [Operation Type](#)
- [Concertation Type](#)
- [Operation and Concertation](#)
- [Marketability](#)
- [Reference](#)
- [Instrument Status](#)
- [Index Status](#)
- [Index Components](#)
- [Trend](#)
- [System Event Codes](#)
- [Types of Public Offerings](#)
- [Settlement Type](#)
- [Market Data Groups](#)
- [Markets](#)
- [Derivatives Market](#)
- [Snapshot Type](#)
- [Type of BIVA Operations](#)
- [BMV State Changes \(Only Consolidated FEED\)](#)
- [BIVA State Changes \(Only Consolidated FEED\)](#)
- [Reasons \(Only Consolidated FEED\)](#)
- [Price Type \(Only Consolidated FEED\)](#)
- [Contacts](#)

Operation Type

Mnemonic	Meaning	Containing in Formats			
		P	O	V	Q
C	CASH	<input type="checkbox"/>	<input type="checkbox"/>		<input type="checkbox"/>
O	PUBLIC OFFERING	<input type="checkbox"/>			
R	REGISTRATION OPERATION	<input type="checkbox"/>			
A	OVERALLOCATION	<input type="checkbox"/>			
S	RECIPROCAL SUBSCRIPTION	<input type="checkbox"/>			

F	PUBLIC BUY OFFERING	<input type="checkbox"/>			
H	TRADES AT CLOSING	<input type="checkbox"/>	<input type="checkbox"/>	<input type="checkbox"/>	<input type="checkbox"/>
M	MEDIUM PRICE	<input type="checkbox"/>			
X	OPERATION BY EXCEPTION	<input type="checkbox"/>			
P	AVERAGE FOR THE DAY	<input type="checkbox"/>	<input type="checkbox"/>	<input type="checkbox"/>	
D	AFTER CLOSING			<input type="checkbox"/>	
N	INAV TRADING	<input type="checkbox"/>	<input type="checkbox"/>	<input type="checkbox"/>	

[\(Back\)](#)



Concertation Type

Mnemonic	Meaning	Format Content			
		P	V	Q	p
C	CROSSING OPERATION	<input type="checkbox"/>		<input type="checkbox"/>	<input type="checkbox"/>
O	ORDER CLOSING	<input type="checkbox"/>		<input type="checkbox"/>	<input type="checkbox"/>
H	OPERATION AT CLOSING PRICE	<input type="checkbox"/>	<input type="checkbox"/>	<input type="checkbox"/>	<input type="checkbox"/>
D	OPERATION AFTER CLOSING	<input type="checkbox"/>	<input type="checkbox"/>		<input type="checkbox"/>
M	OPERATION AT MEDIUM PRICE	<input type="checkbox"/>			<input type="checkbox"/>
P	OPERATION AT AVERAGE PRICE FOR THE DAY	<input type="checkbox"/>	<input type="checkbox"/>		<input type="checkbox"/>
X	BLOCK OPERATIONS BY EXCEPTION	<input type="checkbox"/>			<input type="checkbox"/>

v	VWAP OPERATIONS BY EXCEPTION	<input type="checkbox"/>			<input type="checkbox"/>
w	TWAP OPERATIONS BY EXCEPTION	<input type="checkbox"/>			<input type="checkbox"/>
%	BASKET TRADING	<input type="checkbox"/>			<input type="checkbox"/>
x	OTC RECENT OPERATIONS			<input type="checkbox"/>	
y	OTC AGREED OPERATIONS			<input type="checkbox"/>	
A	BUY AUTO-ENTRY			<input type="checkbox"/>	
B	SELL AUTO-ENTRY			<input type="checkbox"/>	
E	BLOCK TRADE			<input type="checkbox"/>	
F	LEG OF BLOCKTRADE FOR CHAIN OF FORWARDS			<input type="checkbox"/>	
G	LEG OF CHAIN OF FORWARDS			<input type="checkbox"/>	
J	LEG OF CROSSING OF FOREIGN CURRENCY STRATEGY			<input type="checkbox"/>	
K	SELL LEG AUTO-ENTRY OF FOREIGN CURRENCY STRATEGY			<input type="checkbox"/>	
L	BUY LEG AUTO-ENTRY OF FOREIGN CURRENCY STRATEGY			<input type="checkbox"/>	
N	LEG OF FOREIGN CURRENCY STRATEGY			<input type="checkbox"/>	
Q	LEG OF FOREIGN CURRENCY STRATEGY			<input type="checkbox"/>	
R	LEG OF CROSSING OF CHAIN OF FORWARDS			<input type="checkbox"/>	

S	SELL LEG AUTO-ENTRY OF CHAIN OF FORWARDS			<input type="checkbox"/>	
T	BUY LEG AUTO-ENTRY OF CHAIN OF FORWARDS			<input type="checkbox"/>	
U	LEG OF AUCTION OF CHAIN OF FORWARDS			<input type="checkbox"/>	
V	LEG OF ROUND OF CHAIN OF FORWARDS			<input type="checkbox"/>	
W	CHAINS OF FORWARDS			<input type="checkbox"/>	
Y	LEG OF ROLLOVER CROSSING			<input type="checkbox"/>	
Z	SELL LEG AUTO-ENTRY OF ROLLOVER			<input type="checkbox"/>	
a	BUY LEG AUTO-ENTRY OF ROLLOVER			<input type="checkbox"/>	
b	LEG OF ROUND OF ROLLOVER			<input type="checkbox"/>	
c	DEPTH OF ROUND OF CHAIN OF FORWARDS			<input type="checkbox"/>	
d	TRADING OF CHAIN OF FORWARDS			<input type="checkbox"/>	
e	DEPTH OF ROUND			<input type="checkbox"/>	
f	ROUND OF CHAIN OF FORWARDS			<input type="checkbox"/>	
g	ROLLOVER SENTRA			<input type="checkbox"/>	
h	TYPE ROUND			<input type="checkbox"/>	
i	AUCTIONS			<input type="checkbox"/>	
j	LEG OF BLOCK TRADE OF ROLLOVER			<input type="checkbox"/>	

k	LEG OF BLOCK TRADE OF FOREIGN CURRENCY STRATEGY			<input type="checkbox"/>	
l	BLOCK TRADE OF FOREIGN CURRENCY STRATEGY			<input type="checkbox"/>	
m	BLOCK TRADE OF CHAIN OF FORWARDS			<input type="checkbox"/>	
n	BLOCKTRADE OF ROLLOVER			<input type="checkbox"/>	
o	CROSSING OF CHAIN OF FORWARDS			<input type="checkbox"/>	
p	SELL AUTO-ENTRY OF CHAIN OF FORWARDS			<input type="checkbox"/>	
q	BUY AUTO-ENTRY OF CHAIN OF FORWARDS			<input type="checkbox"/>	
r	SWAP BLOCK TRADE			<input type="checkbox"/>	
s	SWAP BLOCK TRADE WITH CONTINUOUS COUPON			<input type="checkbox"/>	
t	BLOCK TRADE OF UNWIND			<input type="checkbox"/>	
u	BLOCK TRADE OF SUBSTITUTION			<input type="checkbox"/>	
z	VOICE OVER			<input type="checkbox"/>	
#	FIRM ORDER			<input type="checkbox"/>	
l	IPO CROSS				<input type="checkbox"/>
+	UNINTENTIONAL SELF CROSS				<input type="checkbox"/>
&	WITHOUT CONCERTATION			<input type="checkbox"/>	
(INAV TO CLOSING PRICE TRADING	<input type="checkbox"/>	<input type="checkbox"/>		<input type="checkbox"/>

&rparr;	INAV AFTER CLOSING				
---------	--------------------	-----------------------------------------------------------------------------------	-----------------------------------------------------------------------------------	--	-------------------------------------------------------------------------------------

[\(Back\)](#)

Operation VS Concertation

Transaction	Operation	Concertation
Cash	C	O
Cross	C	C
Public Offering	O	C
Registry Order	R	C
Overallocation	A	C
Reciprocal Subscription	S	C
Public Purchase Offering	F	C
Trades at Closing Price	H	H
Trades After Closing	C	D
Average of the Day Transactions	C	P
Mid-Price Transactions	M	M
Block Trade	X	X
Simple Average Price	X	w
Weighted Average Price	X	v
Basket Trade	X	%

[\(Back\)](#)

Marketability

Mnemonic	Channel 0 Catalogue	Meaning
A	AL	HIGH
M	ME	MEDIUM
B	BA	LOW
N	MI	MINIMUM
R	RC	RECENT QUOTATION
" "	NU	NULL OR INAPPLICABLE

[\(Back\)](#)

Reference

Mnemonic	Channel 0 Catalogue	Meaning	Format Content			
			a	c	f	b
N	AN	PREVIOUS	<input type="checkbox"/>	<input type="checkbox"/>	<input type="checkbox"/>	<input type="checkbox"/>
J	AJ	ADJUSTED	<input type="checkbox"/>	<input type="checkbox"/>	<input type="checkbox"/>	
" "	" "	WITHOUT PRICE	<input type="checkbox"/>	<input type="checkbox"/>	<input type="checkbox"/>	<input type="checkbox"/>
V	VA	ADJUSTED FACE VALUE				<input type="checkbox"/>

[\(Back\)](#)

Instrument Status

H2H Mnemonic	Multicast Mnemonic	Meaning	Description
CP	C	CANCELLATION OF OFFERS	During the auction session from 7: 50-7: 59: 59 the cancellation of the offers that are in force can be performed, during this period the values will be presented as status: "C" (Cancellation of Offers)
SP	A	OPENING AUCTION	During the stage session of the auction between 8: 00-8: 29: 59 will be allowed the entry, the modification of offers with the possibility to conciliate operations. In this period the values will change their status to "SP=A" (Opening Auction)
PA	P	PRE-OPENING	In this stage will appear the instruments of FIXED INCOME AND WARRANT, and it wouldn't be possible to perform the match of these. (8: 00-8: 25: 00)
EA	E	BEING ALLOCATED	The instruments will be placed in an assigned state when the system has made the matching of the orders generated during the auction (auction period between 8: 25: 00-8: 29: 59, applied to equities and derivatives).
AS	G	AUCTION ALLOCATED	The instruments are placed at this stage when the matches derived from the auction have already made. (8: 25-8: 29: 59)
ST	T	AUCTION ENDED	In this stage, instruments that have no match operations will appear. (8: 25-8: 29: 59)

AP	N	CONTINUOUS TRADING	"The instruments will take this status to indicate that they are tradeable (period 8: 30-15: 00)
SU	K	BREAKING AUCTION PARAMETERS	The Posture that exceeds the percentage of variation referred to in the operating manual (1.4.3.1 Extraordinary Fluctuations in the Price) will cause that the value in question be traded through the volatility auction operation scheme (breaking of parameters)
SB	M	CONTINUOUS AUCTION DUE TO STOP OPERATING MORE THAN 20 WORKING DAYS	For the Issuer Values of any tradability (except Securities referenced in Capital Assets that will continue operating in the continuous market) that cease to run for more than 20 business days in the continuous market, will be identified with stage M.
SU	U	CLEAVING AUCTION	In this stage will appear the issuers that make a cleaving and enter pre-auction during the period from 7:30 to 8:00.
SS	O	SUSPENDED SERIES	The Exchange may suspend an issuer during an auction if it is found in the specified cases in the operating manual (1.4 Operation scheme by auction and suspensions)
SC	V	SUSPENDED QUOTATION	The Exchange will have the power to suspend the quotation of a value during the auction if there are extraordinary fluctuations in the price according to what is established in the operating manual.
SL	L	AUCTION FOR BREACH	"The Exchange will suspend the quotation of a value for breach according to the operations

			manual (1.4.3.4 Lack of Delivery of Information and 1.4.3.5 Special Features of Financial Information)
RO	I	WITHDRAWAL OF ORDERS ON CONTINUOUS AUCTION	Once the price of the issuer has been assigned during the auction (auction for breach, breach, to stop operating 20 days or an auction of CKDes), it will change its status to RO=I (withdrawal of orders), in which only the withdrawal will be allowed, but the registration of postures don't.
SA	B	WITHDRAWAL OF ORDER ON INTRADAY AUCTION	After an issuer is suspended, it enters into withdrawal of an order to enter an intraday auction and if price is agreed, it enters into continuous trading. (8: 30-15: 00)
NP	W	NEWS PENDING	The Stock Exchange could allow during the suspension of the quotation that the stage of the of the value be "News Pending" or "W" (Operational Manual 1.4.3.1 Extraordinary Fluctuations in Price / d))
Only for Derivatives Market	X	SETTLEMENT AUCTION	This stage is only presented for derivative market instruments. The instruments will be placed on that stage during the auction period to determine settlement prices (2:10 a.m. to 2:15 a.m.)
Only for Derivatives Market	Y	EXTRAORDINARY SETTLEMENT AUCTION	In cases of controversy with the settlement price, MexDer may conduct an extraordinary auction, to determine the settlement price again.
New	R	AUCTION TOTAL OF CKDES	Only for the CKDes (8:30-14:00)

[\(Back\)](#)

Index Status

Mnemonic	Meaning
A	PREVIOUS
P	PRELIMINARY
D	FINAL

[\(Back\)](#)

Indices Components

Indices	Component	Sector	Type
S&P/BMV IPC CompMx	60	0	E
S&P/BMV Brazil 15 Indices	BB	0	E
S&P/BMV IPC MidCap	CG	0	E
S&P/BMV IPC SmallCap	CM	0	E
S&P/BMV IPC LargeCap	CP	0	E
S&P/BMV China SX20 Indices	CX	0	E
S&P/BMV Market Makers Indices	FM	0	E
S&P/BMV INMEX	IM	0	E
S&P/BMV Mexico-Brazil Indices	MB	0	E
S&P/BMV IPC	ME	0	E
S&P/BMV Materials Sector Indices	SE	2	E
S&P/BMV Industrials Sector Indices	SE	3	E
S&P/BMV Consumer Discretionary Sector Indices	SE	4	E

S&P/BMV Consumer Staples Sector Indices	SE	5	E
S&P/BMV Health Care Sector Indices	SE	6	E
S&P/BMV Financials Sector Indices	SE	7	E
S&P/BMV Telecommunication Services Sector Indices	SE	9	E
S&P/BMV Materials Select Sector Indices	SN	1	E
S&P/BMV Industrials Select Sector Indices	SN	2	E
S&P/BMV Consumer Staples Select Sector Indices	SN	3	E
S&P/BMV Financials Select Sector Indices	SN	5	E
S&P/BMV Brazil 15 Indices TR	BT	0	E
S&P/BMV China SX20 Indices TR	CT	0	E
S&P/BMV Consumer Discretionary Sector Indices TR	ET	4	E
S&P/BMV Consumer Staples Sector Indices TR	ET	5	E
S&P/BMV Consumer Staples Select Sector Indices TR	ST	3	E
S&P/BMV Financials Sector Indices TR	ET	7	E
S&P/BMV Financials Select Sector Indices TR	ST	5	E
S&P/BMV Health Care Sector Indices TR	ET	6	E
S&P/BMV Industrials Sector Indices TR	ET	3	E
S&P/BMV Industrials Select Sector Indices TR	ST	2	E
S&P/BMV INMEX TR	IT	0	E
S&P/BMV IRT	RT	0	E

S&P/BMV IRT CompMx	R6	0	E
S&P/BMV IRT LargeCap	RP	0	E
S&P/BMV IRT MidCap	RG	0	E
S&P/BMV IRT SmallCap	RM	0	E
S&P/BMV Market Makers Indices TR	FP	0	E
S&P/BMV Materials Sector Indices TR	ET	2	E
S&P/BMV Materials Select Sector Indices TR	ST	1	E
S&P/BMV Mexico-Brazil Index TR	MT	0	E
S&P/BMV Telecommunication Services Sector Indices TR	ET	9	E
S&P/BMV FIBRAS Composite Indices (MXN)	FG	0	E
S&P/BMV FIBRAS Composite Indices (MXN) TR	FF	0	E
S&P/BMV Mining & Agriculture Indices	AS	1	S
S&P/BMV Manufacturing, Electricity, & Water Indices	AS	2	S
S&P/BMV Construction Indices	AS	3	S
S&P/BMV Retail & Distributors Indices	AS	4	S
S&P/BMV Infrastructure & Transportation Indices	AS	5	S
S&P/BMV Financial Services Indices	AS	6	S
S&P/BMV Commercial Services Indices	AS	7	S
S&P/BMV IPC CompMx Quality Weighted Indices (MXN)	CN	0	S
S&P/BMV IPC CompMx Quality Indices (MXN)	CS	0	S

S&P/BMV IPC CompMx Risk Weighted Indices (MXN)	CW	0	S
S&P/BMV Dividend Indices	DS	0	S
S&P/BMV IPC CompMx Enhanced Value Indices (MXN)	ES	0	S
S&P/BMV FIBRAS Indices	FB	0	S
S&P/BMV IPC Quality, Value & Growth Indices	IF	0	S
S&P/BMV IPC Quality, Value & Growth Indices TR	FT	0	S
S&P/BMV Housing Indices	IH	0	S
S&P/BMV Ingenius Indices (MXN)	IN	0	S
S&P/BMV IPC CompMx Short-Term Momentum Weighted Indices (MXN)	MM	0	S
S&P/BMV IPC Risk Weighted Indices (MXN)	PR	0	S
S&P/BMV IPC CompMx Short-Term Momentum Indices (MXN)	SC	0	S
S&P/BMV Bursa Optimo Indices	VD	0	S
S&P/BMV Bursa Optimo Indices TR	VT	0	S
S&P/BMV Commercial Services Indices TR	AT	7	S
S&P/BMV Construction Indices TR	AT	3	S
S&P/BMV Dividend Indices TR	DT	0	S
S&P/BMV FIBRAS Indices TR	FR	0	S
S&P/BMV Financial Services Indices TR	AT	6	S
S&P/BMV Housing Indices TR	HT	0	S

S&P/BMV Infrastructure & Transportation Indices TR	AT	5	S
S&P/BMV Ingenius Indices (MXN) TR	IR	0	S
S&P/BMV IPC 2X Leverage Daily Indices	DD	0	S
S&P/BMV IPC CompMx Enhanced Value Indices (MXN) TR	ET	0	S
S&P/BMV IPC CompMx Enhanced Value Indices (USD)	EU	0	S
S&P/BMV IPC CompMx Enhanced Value Indices (USD) TR	ER	0	S
S&P/BMV IPC CompMx Enhanced Value Weighted Indices (MXN)	VM	0	S
S&P/BMV IPC CompMx Enhanced Value Weighted Indices (MXN) TR	TI	0	S
S&P/BMV IPC CompMx Enhanced Value Weighted Indices (USD)	VU	0	S
S&P/BMV IPC CompMx Enhanced Value Weighted Indices (USD) TR	TV	0	S
S&P/BMV IPC CompMx Quality Indices (MXN) TR	TS	0	S
S&P/BMV IPC CompMx Quality Indices (USD)	QS	0	S
S&P/BMV IPC CompMx Quality Indices (USD) TR	TQ	0	S
S&P/BMV IPC CompMx Quality Weighted Indices (MXN) TR	RC	0	S
S&P/BMV IPC CompMx Quality Weighted Indices (USD)	QU	0	S
S&P/BMV IPC CompMx Quality Weighted Indices (USD) TR	QT	0	S
S&P/BMV IPC CompMx Risk Weighted Indices (MXN) TR	CR	0	S

S&P/BMV IPC CompMx Risk Weighted Indices (USD)	CU	0	S
S&P/BMV IPC CompMx Risk Weighted Index (USD) TR	UT	0	S
S&P/BMV IPC CompMx Short-Term Momentum Indices (MXN) TR	ST	0	S
S&P/BMV IPC CompMx Short-Term Momentum Indices (USD)	SU	0	S
S&P/BMV IPC CompMx Short-Term Momentum Indices (USD) TR	US	0	S
S&P/BMV IPC CompMx Short-Term Momentum Weighted Indices (MXN) TR	RI	0	S
S&P/BMV IPC CompMx Short-Term Momentum Weighted Indices (USD)	TM	0	S
S&P/BMV IPC CompMx Short-Term Momentum Weighted Indices (USD) TR	RD	0	S
S&P/BMV IPC CompMx Trailing Income Equities ESG Tilted Indices (MXN)	GM	0	S
S&P/BMV IPC CompMx Trailing Income Equities ESG Tilted Indices (MXN) TR	TH	0	S
S&P/BMV IPC Inverse Daily Indices	DI	0	S
S&P/BMV IPC Risk Weighted Indices (MXN) TR	PT	0	S
S&P/BMV IPC Risk Weighted Indices (USD)	PU	0	S
S&P/BMV IPC Risk Weighted Indices (USD) TR	TR	0	S
S&P/BMV Manufacturing, Electricity, & Water Indices TR	AT	2	S
S&P/BMV Mining & Agriculture Indices TR	AT	1	S
S&P/BMV MXN-USD Currency Indices	MU	0	S

S&P/BMV Retail & Distributors Indices TR	AT	4	S
S&P/BMV USD-MXN Currency Indices	UM	0	S
S&P/BMV Total Mexico ESG Indices (MXN)	EE	0	G
S&P/BMV Total Mexico ESG Indices (MXN) TR	EG	0	G
S&P/BMV IPC ESG Tilted Indices (MXN)	ML	0	G
S&P/BMV IPC ESG Tilted Indices (MXN) TR	EL	0	G
S&P/BMV IPC ESG Tilted (Light) Indices (MXN)	MP	0	G
S&P/BMV IPC ESG Tilted (Light) Indices (MXN) TR	EP	0	G
S&P/BMV IPC ESG Tilted (Moderate) Indices (MXN)	MW	0	G
S&P/BMV IPC ESG Tilted (Moderate) Indices (MXN) TR	EW	0	G
S&P/BMV IPC ESG Tilted (Heavy) Indices (MXN)	MY	0	G
S&P/BMV IPC ESG Tilted (Heavy) Indices (MXN) TR	EY	0	G
S&P/BMV IPC CompMX Consumer Staples	AC	5	E
S&P/BMV IPC CompMX Consumer Staples TR	AR	5	E
S&P/BMV IPC CompMX Financials	AC	7	E
S&P/BMV IPC CompMX Financials TR	AR	7	E
S&P/BMV IPC CompMX Materials	AC	2	E
S&P/BMV IPC CompMX Materials TR	AR	2	E
S&P/BMV IPC CompMX Industrials	AC	3	E
S&P/BMV IPC CompMX Industrials TR	AR	3	E

S&P/BMV IPC CompMX Communication Services	AC	9	E
S&P/BMV IPC CompMX Communication Services TR	AR	9	E
S&P/BMV IPC CompMX Consumer Discretionary	AC	4	E
S&P/BMV IPC CompMX Consumer Discretionary TR	AR	4	E

[\(Back\)](#)

Trend

Mnemonic	Meaning
A	INCREASE
B	DECREASE
S	WITHOUT CHANGE
" "	WITHOUT OPERATION

[\(Back\)](#)

System Event Codes

Market	Mnemonic	Meaning	Detail	Applicability
For Equities and Derivative	A	Start of system hours	Time when the applications are up and messages begin to be transmitted, but it is not yet possible to start trading approx. 05:30	*
Trading stages for Equities	B	Cancelation of offers	7:50-7:59:59	*
	C	Start of Opening Auction	8:00-8:25:00	*
	D	Start of continuous market	8:30-15:00:00	*
	E	Start of WAP period	14:40:00	*
	F	Continuous market ends	15:00:00	*
	G	Start of after-closing phase	15:01:00	*
	H	It ends after closing	15:10:00	*
	J	Transmission of final prices ends	15:13:00	Not applicable Consolidate Feed
For Equities and Derivatives	K	End of system hours	Time when the applications are down approx. 20:00	*

Comentado [ACO1]: traduccion

For Equities and Derivatives	M	Start of administrative recess	Cancellation of offers	*
	N	End of administrative recess	Only in case of trading Recess	*
Trading stages for Derivatives	O	Start DV/MA/MX markets	Derivatives market start: Rates and Currencies (DV), Dollar options (MA) and Capital Markets (MX) (7:30:00)	Not applicable Consolidate Feed
	P	End of DV/MA markets	End of Market for Rates and Currencies (DV) and Dollar Options (MA) (14:00)	Not applicable Consolidate Feed
	Q	End of MX markets	End of Market for Equities Market (MX) (15:00)	Not applicable Consolidate Feed
	R	Start of OPC modality	Start of operation at settlement prices (For MX 15:20, for DV 14:25)	*
	S	End of OPC modality	End of trading at settlement prices (For MX 15:30, for DV 14:35)	*
	T	Start of settlement auction	Start of settlement auction for DV/MA Markets (14:10)	*
	U	End of settlement auction	End of settlement auction for DV/MA Markets (14:15)	*
	V	Final register of settlement prices	Final register of settlement prices approx. 16:00	Not applicable Consolidate Feed

Comentado [ACO2]: Falta traducción

Derivatives	W	Open interest	Information sent by Asigna from the information of the liquidating partners (18:00 approx)	Not applicable Consolidate Feed
-------------	---	---------------	--------------------------------------------------------------------------------------------	---------------------------------

* Applies both INTRA Multicast and the Consolidate Feed

Comentado [ACO3]: traduccion

[\(Back\)](#)

Catalog of Types of Public Offerings

Mnemonic	Meaning
P	Public offering
R	Registration operation
C	Buy public offering
A	Overallocation
S	Reciprocal subscription

[\(Back\)](#)

Settlement Type

Mnemonic	Meaning
M	Same Day
2	24 hours
4	48 hours
7	72 hours
9	96 hours
1	120 hours

[\(Back\)](#)

Market Data Groups

Identifier	Description
1	in-depth local market
2	in-depth global market
3	20 price levels of local market
4	20 price levels of global market
5	Best offers of local market
6	Best offers of global market
7	10 price levels of derivative futures
8	10 price levels of derivative options
9	Best offers for derivative futures



10	Best offers for derivative options
11	Money market
12	Indices Components
13	Level of Indices
14	Levels of INAV's
15	In-depth local and global market
16	20 price levels of local and global market
17	Best offers of local and global market with Money market
18	20 price levels of local and global Market, Indices components, level of Indices and levels of INAV's
19	10 price levels of derivate futures and derivative options
20	Best offers for derivative futures and derivative options
21	Added Value with Benchmark
22	Added Value with Capitalization Rules
23	Indices Levels with delay
24	Local and Global market with Money market best positions with delay
25	Equities market trades, Consolidated Feed
26	Best bid of the equities market, Consolidated Feed
27	Full depth, Consolidated Feed
28	Closing price origin
29	Analytics "Price and Market Depth"

32	Analytics "Market Quality"
33	Analytics "Spead Performance"
34	Analytics "Negotiation"
40	Channel Zero (catalogs)

[\(Back\)](#)

Markets

Mnemonic	Meaning	Format Content		
		a	b	S
L	Local	<input type="checkbox"/>		
G	Global (Foreign Instruments)	<input type="checkbox"/>		<input type="checkbox"/>
D	Local debt		<input type="checkbox"/>	
F	Global debt		<input type="checkbox"/>	
E	Money		<input type="checkbox"/>	
M	Dollar option market (MA)			<input type="checkbox"/>
X	Stock Market (MX)			<input type="checkbox"/>
V	FOREX and rates Market (DV)			<input type="checkbox"/>
J	Fixed Income			<input type="checkbox"/>
B	Variable Income			<input type="checkbox"/>
T	Metals			<input type="checkbox"/>

I	Mutual Funds			
W	Warrants			
Empty/Blank	All Markets			

[\(Back\)](#)

Derivatives Market

Market	Value Type
MX	OA
MX	FA
MX	FW
MX	FI
MX	OI
MA	OD
MA	FC
DV	FU
DV	FB
DV	FS
DV	FT
DV	FD

[\(Back\)](#)

Snapshot Type

Value	Description	Market Data Groups	Formats
0	List of Instruments (This snapshot will be eliminated on August 1st, 2022)	1, 2, 3, 4, 5, 6, 7, 8, 9, 10, 11, 14, 15, 16, 17, 18, 19, 20, 21, 24	a, c, e, f, d, b, g, y
1	Full depth	1, 2, 15, 24	A, 4
2	Price levels	3, 4, 7, 8, 16, 18, 19	1, 4
3	Best offers	1, 2, 3, 4, 5, 6, 9, 10, 15, 16, 17, 18, 20, 24	O, 4
4	Trades	1, 2, 3, 4, 5, 6, 7, 8, 9, 10, 11, 15, 16, 17, 18, 19, 20, 24	P, H, 4, M
5	Instrument's catalog, full depth, tradability and trades (catalogs will be eliminated from snapshot on August 1st 2022)	1, 2, 15	*catalog, 4, A, E, P
6	Instrument's catalog, price levels, tradability and trades (catalogs will be eliminated from snapshot on August 1st, 2022)	3, 4, 7, 8, 16, 18, 19	*catalog, 4, 1, E, P
7	Instrument's catalog, best offers and trades (catalogs will be eliminated from snapshot on August 1st, 2022)	5, 6, 9, 10, 17, 20, 24	*catalog, 4, O, P
8	Instrument's catalog, full depth, tradability and price setter trade (catalogs will be eliminated from snapshot on August 1st 2022)	1, 2, 15	*catalog, 4, A, E, P
9	Instrument's catalog, price levels, tradability and price setter trade (catalogs will be eliminated from snapshot on August 1st 2022)	3, 4, 7, 8, 16, 18, 19	*catalog, 4, 1, E, P

Comentado [ACO4]: traduccion

10	Instrument's catalog, best offers and price setter trade (catalogs will be eliminated from snapshot on August 1st, 2022)	5, 6, 9, 10, 17, 20, 24	*catalog, 4, O, P
11	General Indices	13, 18, 23	U
12	Instrument's catalog, price levels, best offers and tradability (catalogs will be eliminated from snapshot on August 1st 2022)	18	*catalog, 4, 1, O, E
13	Instrument's catalog, Consolidated Feed	25, 26, 27	h, 0, ., [, T
14	Trades, Consolidated Feed	25	p
15	Best offers, Consolidated Feed	26	m
16	Full depth, Consolidated Feed	27	n
17	Best offers and trades, Consolidated Feed	25, 26	*catalog, 9, m,p
18	Full depth and trades, Consolidated Feed	25, 27	*catalog, 9, n,p

Agile Snapshots

Snapshot Type 19

1. In case the channel includes the status change format (4), it will send this message only for those instruments that have had a status change during the day.
2. In the event that the channel includes the tradability format (E), it will send this message only on those instruments that have had operations during the day.
3. If the channel does not include the tradability format (E), it will send the last event (P or Q depending on a capital or derivatives channel) that has set a price only for each of the instruments that have operated on the day.
4. If the channel includes both the trade format (P or Q) and the tradability format (E), it will only send the operational format (E) according to the rule described in point number 2.
5. In case the channel includes the depth format (1) or the best offer (O), the snapshot will only send the messages that have any value, that is, the values in zeros to identify empty circle will not be sent.
6. For channel 14 (INAV levels), only the last INAV (G) format that has had operation will be sent.

Snapshot Type 20

- It will send the latest trades (P format or Q format as the case may be) that have been generated in the last 10 minutes.

Canal INTRA Multicast INTRA Multicast Channel	Snapshot Type 19 (Formats) Snapshot Type 19 (Formats)	Snapshot Type 20 (Formats) Snapshot Type 20 (Formats)
1	4, E	P
2	4, E	P
3	4, E, 1	P
4	4, E, 1	P
5	4, O, P	P
6	4, O, P	P
7	4, Q, 1	Q
8	4, Q, 1	Q
9	4, Q, O	Q
10	4, Q, O	Q
11	P	P
14	G	n/a
15	4, E	P
16	4, E, 1	P
17	4, O, P	P
18	4, E, 1	P

19	4, Q, 1	Q
20	4, Q	Q
24	4, O, P	P

[\(Back\)](#)

Type of BIVA Operations

Mnemonic	Meaning
E	Continuous electronic trading.
C	Market on close (MOC).
B	Block trading.
D	Debt trading.
W	Warrants trading.

[\(Back\)](#)

BMV State Changes (Only Consolidated Feed)

Mnemonic	Meaning
C	Bids Cancellation
A	Opening Bidding Session
P	Pre-Opening
E	In Allotment
G	Assigned Bidding Session

T	Ended Bidding Session
N	Ongoing Trading
K	Bidding Session due to parameters breaking
M	Ongoing Bidding Session due to operations ceasing for more than 20 business days
U	Demerger (Spin Off) Bidding Session
O	Suspended Series
V	Suspended Listing
L	Bidding Session due to Breach
I	Withdrawal of Orders in an Ongoing Bidding Session
B	Withdrawal of Orders in Intraday Bidding Session
W	Awaiting News
X	Settlement Bidding Session
Y	Extraordinary Settlement Bidding Session
R	Ckdes Total Bidding Session

[\(Back\)](#)

BIVA State Changes (Only Consolidated Feed)

Types of snapshots allowed by each of the multicast products.

Mnemonic	Meaning
V	Suspended instrument
T	Active instrument

[\(Back\)](#)

Reasons (Only Consolidated Feed)

Reason for the change of status.

Mnemonic	Meaning
N	Normal operation
H	Volatility bidding session
A	Startup of the volatility bidding session
B	End of the volatility bidding session
Q	Awaiting news
S	"Static Price band breach"
M	Suspension due to markets surveillance
O	Suspension from the market of Origin
C	Without compliance
I	Startup of the interest notice

[\(Back\)](#)

Price Type (Only Consolidated Feed)

Price Type allowed by each of the multicast products.

Mnemonic	Meaning
R	Reference
C	Closing Price
I	INAV (for ITCH INDEX only)
V	Volume-Weighted Average Price

[\(Back\)](#)

Contacts

Contacts Information

Area	Correo	Teléfono
Sales Market Data	marketdatasales@grupobmv.com.mx	+52 (55) 5342 9063 +52 (55) 5342 9078 +52 (55) 5342 9079
Customer Support Market Data	marketdata@grupobmv.com.mx	+52 (55) 5342 9035 +52 (55) 5342 9017 +52 (55) 5342 9090 +52 (55) 5342 9613 +52 (55) 5342 9002
Administration Market Data	adminmarketdata@grupobmv.com.mx	+52 (55) 5342 9006 +52 (55) 5342 9078 +52 (55) 5342 9081
Help Desk	mds@grupobmv.com.mx	+52 (55) 5342 9445
Networks Area	stafftelecom@grupobmv.com.mx	
Support H2H	soporte_h2h@grupobmv.com.mx	(5255) 5342 9455

[\(Back\)](#)